

EQUIPMENT MAINTENANCE CHART

AER 500 MICROAIRE DAF® SYSTEM

LOC	TASK	DAILY	WEEKLY	MONTHLY	3 MONTHS	6 MONTHS	YEARLY
1	CHECK THAT AERATION SYSTEM PRESSURES ARE AS SPECIFIED (80 - 110 PSI AT HEADER 12-22 PSI LESS AT SAT TANK)	✓	-	-	-	-	-
2	CHECK THAT AIR SUPPLY PRESSURE AT THE INLET OF THE FILTER/REGULATOR IS AT LEAST 20 PSI HIGHER THAN PRESSURE IN THE HEADER	✓	-	-	-	-	-
3	CHECK THAT AIR FLOW METER INDICATOR BALL IS IN THE "GREEN" RANGE	✓	-	-	-	-	-
4	CHECK THAT VENT LINE IS EXPELLING AIR AND WATER (APPROX 50%/50%)	✓	-	-	-	-	-
5	DRAIN CONDENSATE FROM AIR FILTER	✓	-	-	-	-	-
6	LUBE BEARING IN ELECTRIC MOTOR FOR RECYCLE PUMP	REFER TO MANUFACTURERS LITERATURE IN MANUAL					

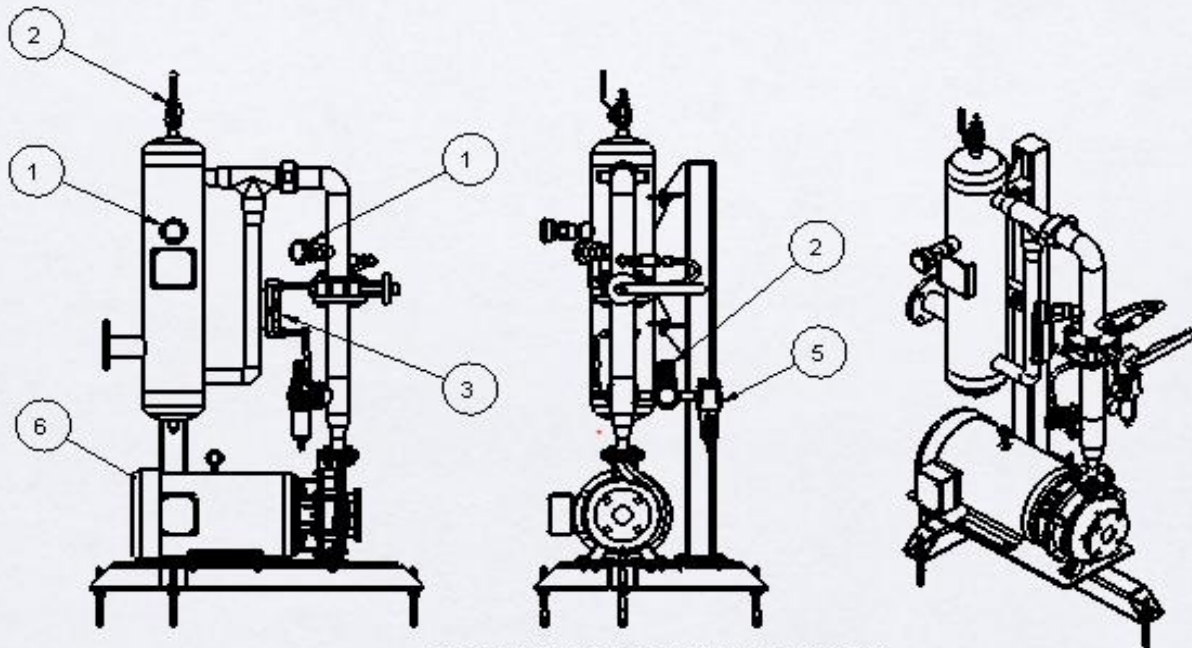

NOTE: VIEWS SHOWN ARE GENERAL REPRESENTATIONS OF STAND ALONE AERATION UNITS. COMPONENT ARRANGEMENT MAY VARY